

Structural & Design Features:

- Parallel Shaft Two-Stage Gear Reducer
- Induction Hardened Teeth on all Gears and Pinions
- Die Cast Aluminum Housing, Precision Machined for Accurate Shaft Alignment
- Pinions Cut Integral with Shafts
- Ball Bearings on Output Shaft
- Adaptor for Face-Mounting NEMA 56C Motor (with 5/8" Diameter Shaft, 3/16" Keyway)
- Helical Gearing Available for Industrial and Commercial OEM Applications

Output Options:

- Available with 10 Gear Ratios (See Chart Below)



Dimensions and Ratings

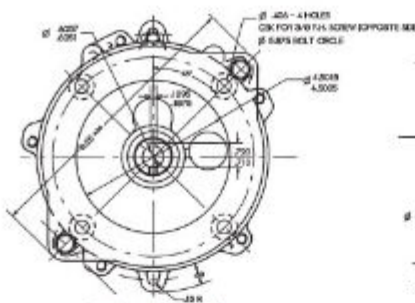

Rear View (Input end)
Mounting Dimensions for NEMA 56C Motor

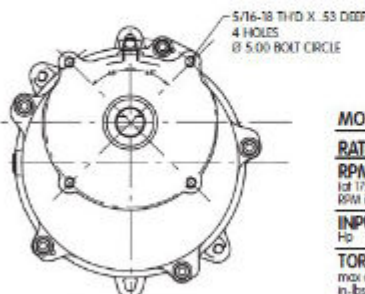
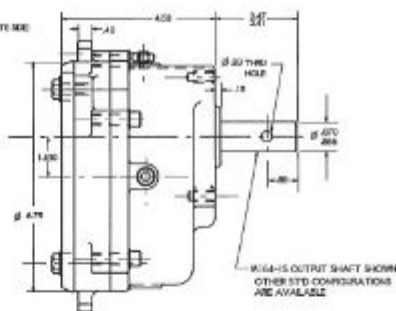

Front View (Output end)

MODEL	M164-X	M164-E	M164-A	M164-L	M164-B	M164-F	M164-K	M164-C	M164-D	M164-G
RATIO	11.08	9.11	7.63	6.48	5.56	4.81	4.18	3.91	3.20	2.63
RPM_{out} (at 1725 RPM _{in})	156	189	226	266	310	358	412	441	539	657
INPUT HP	0.75	0.90	1.07	1.25	1.48	1.48	1.48	1.48	1.48	1.48
TORQUE max output in. lbs.	290	294	285	290	290	255	231	204	167	140

All data is for an Operating Service Factor of 1 at 1725 RPM input speed (consult Mfg. for allowable overhung loads and for additional output shaft configurations)